

MANUAL

FIELD BARRIER



With regard to the supply of products, the current issue of the following document is applicable: The General Terms of Delivery for Products and Services of the Electrical Industry, published by the Central Association of the Electrical Industry (Zentralverband Elektrotechnik und Elektroindustrie (ZVEI) e.V.) in its most recent version as well as the supplementary clause: "Expanded reservation of proprietorship"

1	Introduction	3
2	Validity of these instruction manual	4
3	Symbols used	5
4	Instruction manual	6
4.1	Intended use	6
4.2	Marking	7
4.3	Ambient conditions	7
4.4	Mounting and dismantling	7
4.4.1	Mounting and dismantling the F2D0-FB-Ex4.***	7
4.4.2	Mounting/dismounting of RD0-FB-Ex4	7
4.5	Commissioning and installation	8
4.5.1	Commissioning and installation of the F2D0-FB-Ex4.***	9
4.5.2	Commissioning and installation of RD0-FB-Ex4	10
4.6	Grounding / shielding of the F2D0-FB-Ex4.*** and RD0-FB-Ex4	10
4.7	Repair and maintenance	11
4.8	Fault elimination	11
4.9	Disposal	11
5	General	12
5.1	Range of application of the FieldBarrier	12
5.2	Introduction to intrinsic safety for fieldbus systems	12
5.2.1	The FISCO model	13
5.2.2	The Entity model	14
5.2.3	Topologies	15
5.2.4	Grounding	17
6	Planning for a fieldbus application	19
6.1	Functional description of the FieldBarrier	19
6.2	Topologies in combination with the FieldBarrier	21
6.2.1	Topologies on intrinsically safe outputs	21
6.2.2	Topologies of the trunk in connection with the FieldBarrier	22
6.3	Dimensioning of a fieldbus segment	23
6.4	Terminating the trunk with a fieldbus terminating resistor.	23
6.5	Mechanical dimensions	24
6.5.1	Mechanical dimensions of the R version	25

7	Commissioning the FieldBarrier	26
7.1	Mounting FieldBarriers	26
7.1.1	Mounting the FieldBarrier F*D0-FB-Ex4.***	26
7.1.2	Handling F*D0-FB-Ex4.CG cable glands	27
7.1.3	Handling the F*D0-FB-Ex4.CGB and F*D0-FB-Ex4.CGS cable gland	28
7.1.4	Handling the F*D0-FB-Ex4.CGAB cable gland	29
7.1.5	Mounting the stop plug	30
7.1.6	Mounting the FieldBarrier RD0-FB-Ex4	30
7.2	FieldBarrier connections	30
7.3	Grounding	31
7.4	Fieldbus termination	31
7.5	Displays and error messages.	32

1 Introduction

The FieldBarrier F*D0-FB-Ex4.*** and RD0-FB-Ex4 connect up to 4 intrinsically safe field devices. It is connected via non-intrinsically safe connections to the trunk of a fieldbus with a physical layer in accordance with IEC 61158-2.

The FieldBarrier works exclusively on the physical layer, which makes it independent of the protocol. This allows it to be substituted for any field bus with a physical layer in accordance with IEC 61158-2. This includes the FOUNDATION fieldbus and the PROFIBUS MBP, for example.



Note

More recent documentation also refers to PROFIBUS MBP in connection with PROFIBUS PA. MBP stands for Manchester Bus powered. PROFIBUS PA and PROFIBUS MBP are identical. The following section refers only to the term PROFIBUS MBP that has just been introduced. PROFIBUS MBP-IS refers to the intrinsically safe version of the PROFIBUS MBP.

The trunk of the fieldbus can be supplied via additional terminals to other FieldBarriers (cascading) or other fieldbus stations.

If the trunk is mounted in increased safety, the FieldBarrier can be mounted in the Zone 1 and Zone 22 (non-conductive dust) of a hazardous area. The terminals for the trunk are designed in increased safety EEx e.

If the FieldBarrier is the last device connected to the trunk, it must be terminated with a fieldbus terminator. A fieldbus terminator is integrated into the FieldBarrier for this purpose, and can be turned on when it is needed.

The trunk is galvanically separated from the outputs. 40 mA per output is available for the intrinsically safe power supply of the field devices. The number of field devices that can actually be operated on an output depends on their power consumption.

The line length per output can be up to 120 m and is operated without a fieldbus terminator. The outputs correspond to the requirements of PTB Report W-53 (FISCO Model.) For additional information on this subject, please refer to chapter 5.2.1

Each output has a voltage and current limit. This prevents the entire fieldbus segment from failing if a fault occurs on just one output.

The technical data can be found in the data sheet.

2 Validity of these instruction manual

This instruction manual describes the following Pepperl+Fuchs products:

- the FieldBarrier F2D0... for panel mounting in aluminum field housings.
- The FieldBarrier RD0... for mounting on a 35-mm top hat section rail in accordance with EN 50 022.



A corresponding declaration of conformity may be requested from the manufacturer.

Note

The manufacturer of the product, Pepperl+Fuchs GmbH in D-68301 Mannheim, has a certified quality assurance program in accordance with ISO 9001.



3 Symbols used



Warning

This symbol warns of a danger.

In the event the warning is ignored, the consequences may range from personal injury to death or from damage to equipment to destruction.



Attention

This symbol warns of a possible fault.

Failure to observe the instructions given in this warning may result in the device and any facilities or systems connected to it developing a fault or even failing completely.



Note

This symbol draws your attention to important information.

4 Instruction manual

These instructions apply in conjunction with the respective data sheets. You can access the data sheets at www.pepperl-fuchs.com.



Warning

The operator of the system bears the responsibility in terms of planning, mounting, commissioning, operation and maintenance, especially in conjunction with applications in areas subject to the danger of explosion.

The data sheet lists the electrical characteristics of the EC declaration of conformity and is considered an integral part of the instruction manual.

4.1 Intended use

The FieldBarrier serves as a galvanic isolation between intrinsically safe and non-intrinsically safe fieldbuses.

The FieldBarrier can be used for all fieldbus systems using "Manchester Coding Bus Powered" physical layout in accordance with IEC 61158-2.

The inputs of the field FieldBarrier are designed in the "Increased safety" ignition protection method. The outputs of the FieldBarrier are designed in the "Intrinsic Safety" ignition protection method and make it possible to operate intrinsically safe field devices.

Data sheets for FieldBarriers contain the electrical data of the EC declaration of conformity and are considered an integral part of the instruction manual.

The FieldBarrier may be installed in hazardous areas of category 2G / Zone 1 and Zone 22 (non-conductive dust).



Warning

FieldBarriers that are operated in general electrical systems must not thereafter be operated in electrical systems that are connected with hazardous areas.

Laws and/or regulations governing the use or intended usage goal must be observed. FieldBarriers are only approved for proper professional usage in accordance with the intended purposes. Improper handling will void any claim made under the warranty and any manufacturer's liability.



Warning

*Protection of operating personnel and the system is not ensured if the module is not **used in accordance with its intended purpose**.*

The device can only be operated by trained professionals in accordance with the available instruction manual.

08/2007 122329

4.2 Marking

FieldBarriers are identified by:

FieldBarrier F2D0-...	FieldBarrier RD0-...
Pepperl + Fuchs	Pepperl + Fuchs
D-68307 Mannheim	D-68307 Mannheim
F2D0-FB-Ex ^{*,***}	RD0-FB-Ex ^{*,***}
PTB 02 ATEX 2086	PTB 02 ATEX 2086
⊕ Ex II 2 (1 G/D) G Ex me [ia] IIC T4	⊕ Ex II 2 (1 G/D) G Ex me [ia] IIC T4
⊕ Ex tD A22 IP54 T135 °C (non-conductive dust)	

4.3 Ambient conditions

For the ambient temperature range, please refer to the respective data sheet.

4.4 Mounting and dismantling

Commissioning and installation must only be performed by specialist who are trained specifically for this purpose.

Recognized rules of the technology and setup requirements must be maintained during mounting and dismantling. Especially for tasks on electrical systems, special safety requirements must be observed. Special attention must be paid to the following points:

1. Has the FieldBarrier been installed in accordance with specifications?
2. Is the FieldBarrier free of damage?

4.4.1 Mounting and dismantling the F2D0-FB-Ex4.***

The housing of FieldBarrier F2D0-FB-Ex4.*** is designed in protection class IP 67. It is intended for panel mounting. 2 screws with a diameter of 6 mm should be used for mounting.

The mounting material should be selected according to the nature of the sub-surface (the wall). When selecting mounting material, care must be taken that it will ensure a secure fastening. The torque to be used for the mounting screws depends on the screws being used.

Type F2D0-FB-Ex4.CG should be mounted so that the cable glands are protected from the effects of mechanical hazards.

The cover screws of the FieldBarrier should be tightened with a torque of 2.5 Nm.

4.4.2 Mounting/dismounting of RD0-FB-Ex4

FieldBarrier RD0-FB-Ex4 is designed for mounting on a 35-mm DIN rail in accordance with EN 50 022. It must be mounted in a housing that corresponds to at least protection class IP 54. The housing must also have an EC declaration of conformity in accordance with EC 94/9.

4.5 Commissioning and installation

The FieldBarrier may be installed according to its designation in Zones 1 and Zone 22 (non-conductive dust) .



The Declaration of conformity must be observed. *It is especially important to maintain any "Special conditions" that may be indicated.*

Warning

When installing intrinsically safe fieldbus segments, EN 60079-14/IEC 60079-14 must be observed. For the Federal Republic of Germany, the "National Foreword" of DIN EN 60079-14/VDE 0165 Part 1 must also be observed.



When using the outputs designated intrinsically safe in Dust-Ex range "D", only field devices certified for this purpose may be connected. When connecting intrinsically safe field devices with the FieldBarrier, the highest level of explosion protection should be considered (Proof of Intrinsic Safety).

Warning

The switch for the internal bus termination can be activated even during operation. The following identifying values must be observed when connecting fieldbus transmission lines:

- For the cable parameters to be observed, please refer to chapter 5.2.1
- The insulating length of the wire is 9 mm
- Wire cross-section 0.2 mm² to 2.5 mm² or AWG 24 to 14
- Whenever finely stranded conductors must be used, the strand ends must be protected from fraying, for example by using end splices.
- Tightening torque of the screw terminals (if present) 0. 4... 0.5 Nm
- Tightening torque of the screwed connections of cable glands for FieldBarriers F2D0...

The tightening torques of the slotted nuts depend on the cable used and must therefore be determined by the user. The cap nuts must be securely tightened. Tightening the cap nuts too tight can have a negative effect on the protection class. The following figures should be taken as rough guides:

Type	Cap nut	Lower part
F2D0-FB-Ex4.CG	2.5 Nm	3.75 Nm
F2D0-FB-Ex4.CGB	4.17 Nm	6.25 Nm
F2D0-FB-Ex4.CGS	4.17 Nm	6.25 Nm
F2D0-FB-Ex4.CGAB	22 Nm	28 Nm

A fieldbus transmission line with an insulation voltage between the bus line and shield of at least 500 V must be used for intrinsically safe fieldbus segments.

4.5.1 Commissioning and installation of the F2D0-FB-Ex4.***

Only permanently laid cables and lines must be inserted into the cable glands.

The screw plugs must only be replaced by cable glands who are adapted for the intended kind of use. By mounting the cable glands pay attention to the according instruction manual.

For the permissible cable diameters, please refer to the respective data sheet. The operator must provide an appropriate strain-relief clamp (for example with a suitable cable clamp). The mounting notes in chapter 4.4 must be observed.

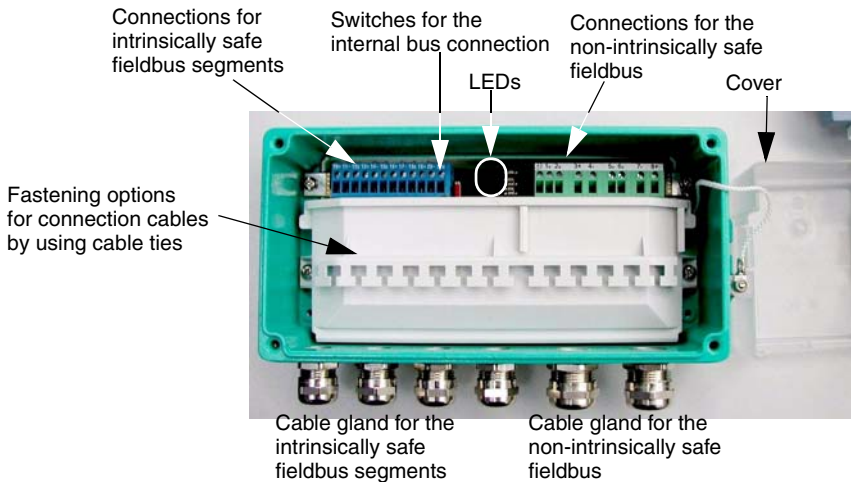

Cable glands that are not in use must be closed off with a corresponding stop plug or replaced by an appropriate screw plug. Stop plugs and screw plugs must have an EC declaration of conformity.



Attention

The ambient temperature range can be restricted by the stop plug. By mounting the cable glands pay attention to the according instruction manual.

For examples of stop plugs and screw plugs, please refer to the respective data sheets.



Attention

In order to maintain the IP 67 protection class, all unused cable glands (M16 and M20) must be plugged with a M20 blind plug.

For metallic housings in hazardous areas, a suitable potential equalization per EN 60 079 is required. A grounding screw is provided on the housing for this purpose. The

connection must be designed to prevent self locking and must be protected against corrosion. Protection against corrosion can also be achieved by using tinned cable plates, for example.



Warning

The cover of the non-intrinsically safe fieldbus connection must only be removed when no electrical power is present.

The connection of the non-intrinsically safe fieldbus connection must only be made when no electrical power is present. After that, the cover must be remounted.

Before closing the cover, a visual inspection must be performed to ensure that there are no visible signs of damage on the cover seal. In the event of damage, the seal must be replaced by an original seal.

The screws on the cover should be tightened to a torque of 2.5 Nm.

4.5.2 Commissioning and installation of RD0-FB-Ex4

The FieldBarrier RD0-FB-Ex4 is mounted on a top-hat rail compliant with EN 50 022.

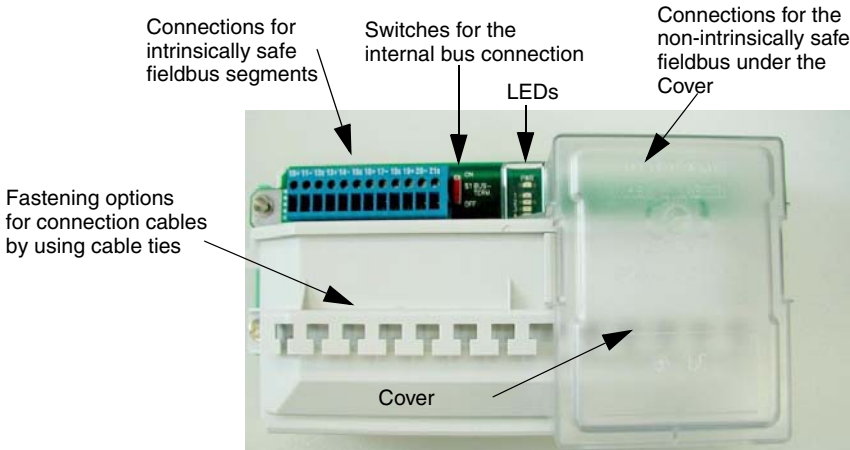

Warning

The cover of the non-intrinsically safe fieldbus connection must only be removed when no electrical power is present.

The connection of the non-intrinsically safe fieldbus connection must only be made when no electrical power is present. After that, the cover must be remounted.

4.6 Grounding / shielding of the F2D0-FB-Ex4.*** and RD0-FB-Ex4

For the FieldBarrier F2D0*** the terminals PA and 1B are electrically connected to the housing.

For the FieldBarrier RD0*** the terminals PA and 1B are electrically connected with both metallic top-hat rail connectors.

The 5S and 6S shield connections of the non-intrinsically safe fieldbus segments are connected internally through a capacitor less than or equal to 5.7 nF with the potential

08/2007 122329

equalization (capacitive grounding of the shield of the trunk). This capacitor can be bypassed with terminals 1B and 2B (hard grounding of the shield of the trunk).

If the shield of the EEx e fieldbus transmission line is grounded for reasons related to EMC, Section 12.2.2.3 of EN 60079-14 and Section 3.3.3 of the PNO introductory manual PROFIBUS PA or Sections 4.1 and 4.4 of the FOUNDATION Fieldbus Application Guides must always be observed.

Each shield connection of intrinsically safe fieldbus segments (12S, 15S, 18S, 21S) is connected internally through a capacitor of less than 12 nF with the potential equalization (capacitive grounding of the shield of the fieldbus transmission line). The cable that is used must be designed for an insulation voltage of at least 500 V between the bus transmission line and the shield.

A hard grounding of the shielding of the intrinsically safe trunk can be implemented with FieldBarriers of types F*D0-FB-Ex4.CGB, F*D0-FB-Ex4.CGS and F*D0-FB-Ex4.CGAB.

4.7 Repair and maintenance

The transmission behavior of the FieldBarrier is stable even over long periods of time. There is thus no need for regular adjustments or similar tasks. Maintenance is therefore not required.

4.8 Fault elimination

FieldBarriers that are operated in connection with hazardous areas must not be modified. If there is a defect, the FieldBarrier must always be replaced.

Defective housing parts (for example cover seals) must be replaced only by original parts. Tasks for eliminating malfunctions must only be performed by specialists who are specially trained and authorized for the task.

4.9 Disposal

Disposal of the packaging and FieldBarrier must only take place in accordance with the requirements of the country in which the FieldBarrier is installed.

The FieldBarrier does not contain any batteries that must be disposed of separately from the FieldBarrier.

5 General

5.1 Range of application of the FieldBarrier

FieldBarriers can be used in combination with fieldbus systems that use the "Manchester Coding Bus Powered" physical layout in accordance with IEC 61158-2. This includes the H1 bus of the FOUNDATION fieldbus and the PROFIBUS MBP, for example. FieldBarriers ensure galvanic isolation between a non-intrinsically safe and an intrinsically safe fieldbus segment.



Note

Both the H1 bus of the FOUNDATION fieldbus and the PROFIBUS MBP use the physical layout described above in accordance with IEC 61158-2. The FieldBarrier can be used for both systems. When the following section refers to the H1 bus, this should be understood to include both the H1 bus of the FOUNDATION fieldbus and the PROFIBUS MBP!

The advantage of the transmission physics in accordance with IEC 61158-2 is that power can be supplied to fieldbus stations from the transmission line. The supply current required for this is made available by power repeaters or power supply units for FOUNDATION Fieldbus and by the segment coupler for the PROFIBUS MBP or PROFIBUS MBP-IS, which is intrinsically safe version of the PROFIBUS MBP.

The following diagram illustrates a typical fieldbus structure in combination with FieldBarriers

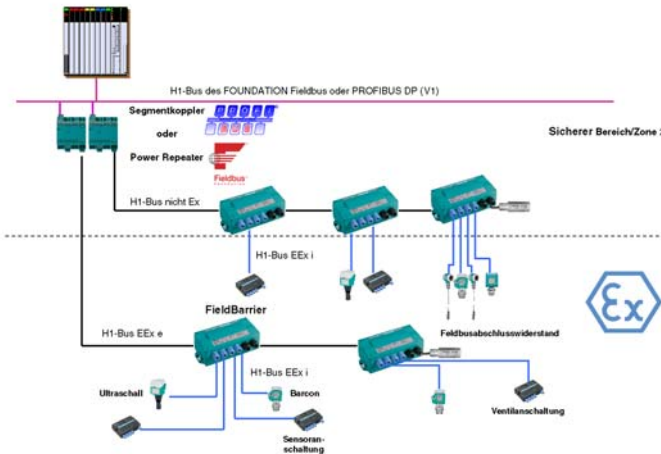

Figure 5.1: Typical field bus structure of intrinsically safe applications

5.2 Introduction to intrinsic safety for fieldbus systems

If fieldbus systems are used in hazardous areas, the corresponding explosion protection measures must be taken. The Intrinsic Safety explosion protection method offers

08/2007 122329

the advantage that fieldbus stations can be disconnected from or connected to the transmission line during ongoing operation.

If a fieldbus segment is designed in Intrinsic Safety ignition protection type, proof of intrinsic safety must be provided. To make this proof of Intrinsic Safety as simple as possible, there are 2 different models:

- the FISCO model
- the Entity model



Warning

Which of the two following models should be used is stipulated by national requirements and/or laws.

Both models are explained briefly below.

5.2.1 The FISCO model

The FISCO model was developed by the German Federal Physical Technical Institute (PTB), which published information on it in Report PTB-W-53 "Examination of intrinsic safety for fieldbus systems". FISCO stands for **F**ieldbus **I**ntrinsically **S**afe **C**oncept and is standardized in the IEC 60079-27. This model is based on the following prerequisites:

1. To transmit electrical power and data, the bus system uses the "Manchester Coding Bus Powered" physical layout in accordance with IEC 61158-2. This is the case for both the FOUNDATION fieldbus and the PROFIBUS MBP.
2. Only one active source is permitted on a bus segment (the power repeater/the segment coupler/the FieldBarrier). All other components work as passive current sinks.
3. The basic current consumption of a bus station is **at least 10 mA**.

4. For each bus device it must be ensured that:

$$\begin{aligned} V_i &\geq V_o \text{ of the Segment coupler/power repeater/FieldBarrier} \\ I_i &\geq I_o \text{ of the Segment coupler/power repeater/FieldBarrier} \\ P_i &\geq P_o \text{ of the Segment coupler/power repeater/FieldBarrier} \end{aligned}$$

5. Each bus station must fulfill the following requirement:

$$\begin{aligned} C_i &\leq 5 \text{ nF} \\ L_i &\leq 10 \text{ }\mu\text{H} \end{aligned}$$

6. The permissible line length for EEx ia IIC applications is 1000 m.
7. The permissible spur length for Ex applications is 60 m per spur line. The definition of the spur must be observed in this connection.
8. The transmission line that is used must conform to the following cable parameters:

Resistor coating: $15 \text{ }\Omega/\text{km} < R' < 150 \text{ }\Omega/\text{km}$

Inductance coating: $0.4 \text{ mH/Km} \leq L' \leq 1 \text{ mH/km}$

Capacitance coating: $45 \text{ nF/km} \leq C' \leq 200 \text{ nF/km}$ (including the shield)

Taking the shield into consideration, the capacitance coating is calculated as follows:

$C' = C'_{\text{conductor/conductor}} + 0.5 * C'_{\text{conductor/shield}}$ if the bus line is potential free or

$C' = C'_{\text{conductor/conductor}} + C'_{\text{conductor/shield}}$ if the shield is connected with a pole of the segment coupler/Power Link.

9. The bus segment must be terminated on both ends of the trunk with a fieldbus terminator. The fieldbus terminator must conform to the following limits:

$$90 \Omega \leq R \leq 100 \Omega$$

$$0 \mu\text{F} \leq C \leq 2.2 \mu\text{F}$$

Given the prerequisite that Points 1 through 9 are **all** satisfied, Proof of Intrinsic Safety has been provided by means of the FISCO model. Points 1, 3 and 5 are automatically satisfied if a product is certified in accordance with the FISCO model.



Warning

*A condition for granting the Proof of Intrinsic Safety according to the FISCO model is that the power source used, here the segment coupler, power repeater, or FieldBarrier, **and** all field devices must be certified in accordance with the FISCO model.*

Furthermore, the cable must meet the requirements of the FISCO model.

For the characteristic Ex values, please refer to the respective EC Declaration of conformity.

5.2.2 The Entity model

The Entity model is based on the observation that the cable represents concentrated inductance and capacitance. The result is that in comparison with the FISCO model less electrical power can be transmitted into the hazardous area. Typical values here are in the vicinity of 10.6 V and 70 mA. As a result,

- fewer stations can be operated on a fieldbus segment
- maximum possible cable lengths are lower than for the FISCO model:

The items 1 through 9 enumerated in chapter 5.2.1 also apply to the Entity model, with the exception of item 5. According to the Entity model, the internal inductance of a field device must be $\leq 20 \mu\text{H}$ and its internal capacitance must be $\leq 5 \text{ nF}$.

For the Proof of Intrinsic Safety according to the the Entity model, it must also be determined for comparison of voltages, currents and outputs that the inductances and capacitances connected to the FieldBarrier do not exceed the maximum permissible values L_0 and C_0 . The following rule applies in general:

$$L_0 \geq L_{\text{cable}} + \sum L_i$$

$$C_0 \geq C_{\text{cable}} + \sum C_i$$

5.2.3 Topologies

Fieldbus topologies are independent of whether an H1 fieldbus segment of the FOUNDATION fieldbus or a PROFIBUS MBP segment is being operated.

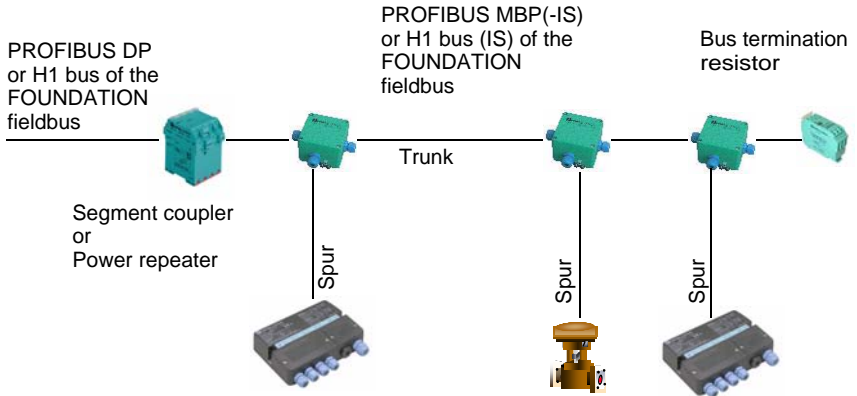

The basic layout of a fieldbus with FieldBarriers is illustrated in Figure 5.1.



Note

The use of FieldBarriers influences possible topologies. For more detailed information, please refer to chapter 6.2.

Two cable types with the following components are essentially recommended for both fieldbus systems:

	Type A	Type B
Cable structure	twisted wire pair, shielded	One or more twisted pairs, total shielding
Conductor cross-section (nominal)	0.8 mm ² (AWG 18)	0.32 mm ² (AWG 22)
Loop resistor (direct current)	44 Ω/km	112 Ω/km
Wave resistance at 31.25 kHz	100 Ω ± 20%	100 Ω ± 30%
Wave attenuation at 39 kHz	3 dB/km	5 dB/km
Capacitive asymmetry	2 nF/km	2 nF/km
Group runtime distortion (7.9 ... 39) kHz	1.7 μs	a
Covering level of the shield	90%	a
Maximum extent of the network for non-intrinsically safe applications	1900 m	1200 m
Maximum extent of the network for intrinsically safe applications	1000 m	a

a. not specified

08/2007 122329

The recommended network expansion is equal to the sum of the trunk and all spurs.
 A fieldbus station works from an input voltage of 9 V, i. e. this value corresponds to the minimum input voltage.



*Please note the specifications of the FieldBarrier. For more detailed information, please refer to **chapter 6.3**.*

Note

With an unfavorable distribution of stations, i.e. if all fieldbus stations are widely removed from the segment coupler/power repeater, it can happen that the voltage drop along the line is so great that the voltage level at the end is insufficient. This results in a shortening of the transmission line or the necessity of using cable with a larger cross-section. Under unfavorable conditions, the following lengths can be achieved with cable type A (0.8 mm² or AWG 18):

- Application EEx ia IIC ==> 860 m
- Non-Ex application ==> 852 m

The fieldbus allows for spurs. The length of each spur is determined by the number of fieldbus stations, the number of field devices per spur and the range of application. The following table shows an overview:

Number of communication members	Maximum spur length for non-Ex applications			
	1 device per spur	2 devices per spur	3 devices per spur	4 devices per spur
1 to 12	120 m	90 m	60 m	60 m
13 to 14	90 m	60 m	30 m	1 m
15 to 18	60 m	30 m	1 m	1 m
19 to 24	30 m	1 m	1 m	1 m
25 to 32	1 m	1 m	1 m	1 m



Please note that the permissible total line length (the total of the trunk and all spurs) must not be exceeded.

Note



For Ex applications the spur length is limited to 60 m per spur.

Warning

For cable type B, multiple fieldbus segments can be carried in one cable. If other types of cable than those recommended are used, the permissible line lengths are reduced.

Following values applies especially for the FieldBarrier:

The maximum cable length per output is limited to 120 meter and may be operated without terminators. The outputs meet the requirements of the IEC 60079-27.

Number of communication members	Maximum spur length
	1 device per output
1 to 12	120 m
13 to 14	90 m
15 to 18	60 m



Note

Consider the master of the PROFIBUS Segment Coupler or the host card at FOUNDATION Fieldbus installations as communication members.

Use the free Segment Checker software to create topologies containing FieldBarriers (www.segmentchecker.com).

5.2.4 Grounding

The cable types described in the previous section, which are recommended for both fieldbus systems, have a shield. For reasons of EMC protection, the shield should be grounded. There are essentially two different ways in which this is possible:

- Double-sided hard grounding of the shield (connection between the shield and potential equalization)
- Capacitive grounding on one end of the shield (connection of the shield to the potential equalization via a capacitor) and hard grounding on the other end
- Hard grounding on one end of the shield and no grounding on the other end

The best EMC protection is achieved with grounding on both ends of the shield. In this case, a potential equalization conductor is required.

If capacitive grounding on one end is used, there is no need for the potential equalization conductor for non-Ex applications. However, the EMC protection is not as good as when the shield is applied on both sides.

If there is a transition from the hazardous area to the safe area with capacitive grounding the capacitor must meet the following requirements:

- It must have a solid dielectric, for example ceramic
- $C \leq 10 \text{ nF}$
- Test voltage $\geq 1500 \text{ V}$



Note

A capacitor which meets the above requirements is integrated into each output in the FieldBarrier. An additional capacitor is not required.

If the shield is only applied on one side, EMC protection is less reliable. In this case as well, there is no need for the potential equalization conductor in the case of non Ex applications.



Warning

Pepperl+Fuchs always recommends the use of shielded lines for the fieldbus. The shield should be hard grounded on the segment coupler/ Power Repeater, FieldBarrier and on all field devices. Please note in this regard chapter 4.6.

For intrinsically safe applications, a potential equalisation between the hazardous and the safe area is required. Note in this regard the respective relevant setup requirements.

If there is no potential equalisation between the hazardous and the safe area, there is a possibility of capacitive grounding on the segment coupler/Power Repeater or FieldBarrier.

The capacitor used must have a fixed dielectric. For the capacitance of the capacitor, the following applies: $C \leq 10 \text{ nF}$. In addition, the capacitor must be designed for a test voltage of $\geq 1500 \text{ V}$.

6 Planning for a fieldbus application

The following section explains how to perform planning for a fieldbus application in combination with the FieldBarrier. This planning is different in a few items

- from planning without a FieldBarrier
- depending on whether a FOUNDATION fieldbus or a PROFIBUS MBP application is being planned.

Explicit mention is made of this in the corresponding places.

6.1 Functional description of the FieldBarrier

The FieldBarrier is used to connect up to 4 intrinsically safe fieldbus stations. It is connected over non-intrinsically safe connections (trunk) with a field device using the "Manchester Coding Bus Powered" physical layout per IEC 61158-2. The trunk of the fieldbus can be supplied via additional terminals to other FieldBarriers (cascading) or other fieldbus stations.



Note

Up to 4 FieldBarriers can be connected to one fieldbus segment.

The FieldBarrier carries out the following tasks:

- Ensuring intrinsic safety on the outputs
- Ensuring galvanic isolation between the non-intrinsically safe fieldbus segment (trunk) and the intrinsically safe fieldbus segment (outputs).
- Connection of the trunk with a fieldbus terminator if the FieldBarrier is the last station on the trunk.



Note

Note the definition of trunk and spur in connection with the FieldBarrier. For more detailed information, please refer to chapter 6.2

A fieldbus terminator that can be turned on and off is integrated into the FieldBarrier for this purpose.

- Power supply of field devices connected to the outputs
- Limit of the short circuit current on each output

If the trunk is mounted in increased safety, the FieldBarrier can be mounted in Zone 1 and Zone 22 (non-conductive dust) of a hazardous area. The terminals for the trunk are designed in increased safety EEx e.

Use in the safe area or in Zone 2 of a hazardous area is also possible.

The trunk is galvanically separated from the outputs. 40 mA per output is available for the intrinsically safe power supply of the field devices.

Each output has a voltage limit and current limit. This offers the advantage of prevent-

ing negative effects on the other outputs and on the trunk if a short circuit occurs on an output, for example.

The cable length on an output can be up to 120 m and is operated without a fieldbus terminator. The outputs meet the requirements of both PTB Report W-53 (FISCO model) and the requirements of the Entity concept. For additional information on this subject, please refer to chapter 5.2.1

The technical data can be found in the data sheet.

Using the FieldBarrier offers the following advantage:

- Limiting the short-circuit current on the output means that only the affected output will fail if there is a short circuit between the FieldBarrier and field device(s). The fieldbus segment continues working.
- Only power repeaters/segment couplers without an intrinsically safe interface are required in addition. This reduces the number of power repeaters/segment couplers that are required.
- No additional junction boxes are required.

Using the "increased safety" explosion protection type causes the maximum permissible current on the EEX e side to be limited only by the power repeater (for a FOUNDATION fieldbus) or segment coupler (for PROFIBUS MBP) that is used.

Depending on the power repeaters/segment coupler that is used, the current consumption of field devices and the current consumption of the FieldBarriers, it may be possible to operate more field devices on a fieldbus segment.

Connections for the non-intrinsically safe fieldbus segment

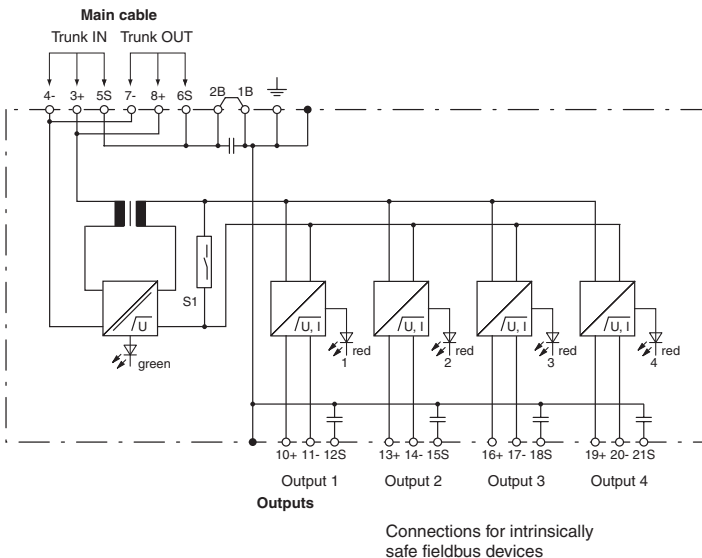

S1: Fieldbus termination, switchable

Figure 6.1: Block diagram of the FieldBarrier

08/2007 122329

6.2 Topologies in combination with the FieldBarrier

Using the FieldBarrier affects the possible topologies of a fieldbus application.

The physical layout used for the H1 bus of the FOUNDATION fieldbus or the PROFIBUS MBP allows for spurs with both Ex and non Ex applications. The permissible length of spurs depends on

- the area of application (Ex or non Ex application; see also chapter 5.2.3).
- the number of stations running on the trunk.
- the number of stations per spur (see also chapter 5.2.3).

The permissible length of spurs is limited by the FISCO model, especially for Ex applications.

The FieldBarrier has galvanic isolation between the trunk and the outputs. From the point of view of the FISCO and Entity model, the secondary side of the transformer integrated for galvanic isolation represents a source.



Note

From the point of view of the FISCO and Entity model, an output of the FieldBarrier represents the supply source for the intrinsically safe fieldbus segment.

*This opens a new, **intrinsically safe** fieldbus segment.*

The maximum permissible cable length on an intrinsically safe output of the FieldBarrier is 120 m. It is operated without fieldbus terminator.

6.2.1 Topologies on intrinsically safe outputs

As a general rule, only one field device can be operated per FieldBarrier output. Because of the short-circuit current limiting and absence of retro-action in the FieldBarrier, this offers the advantage of increased system availability.

This results in the following topology of intrinsically safe outputs:

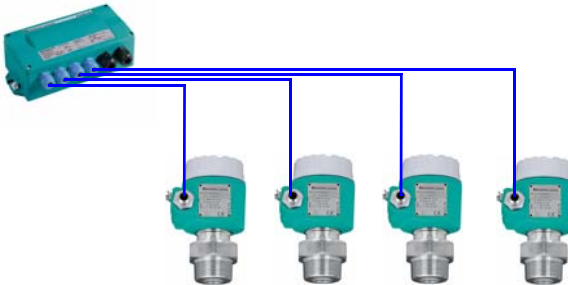

Figure 6.2: Output topology

08/2007 122329

6.2.2 Topologies of the trunk in connection with the FieldBarrier

There are 2 possible topologies for the non-intrinsically safe trunk:

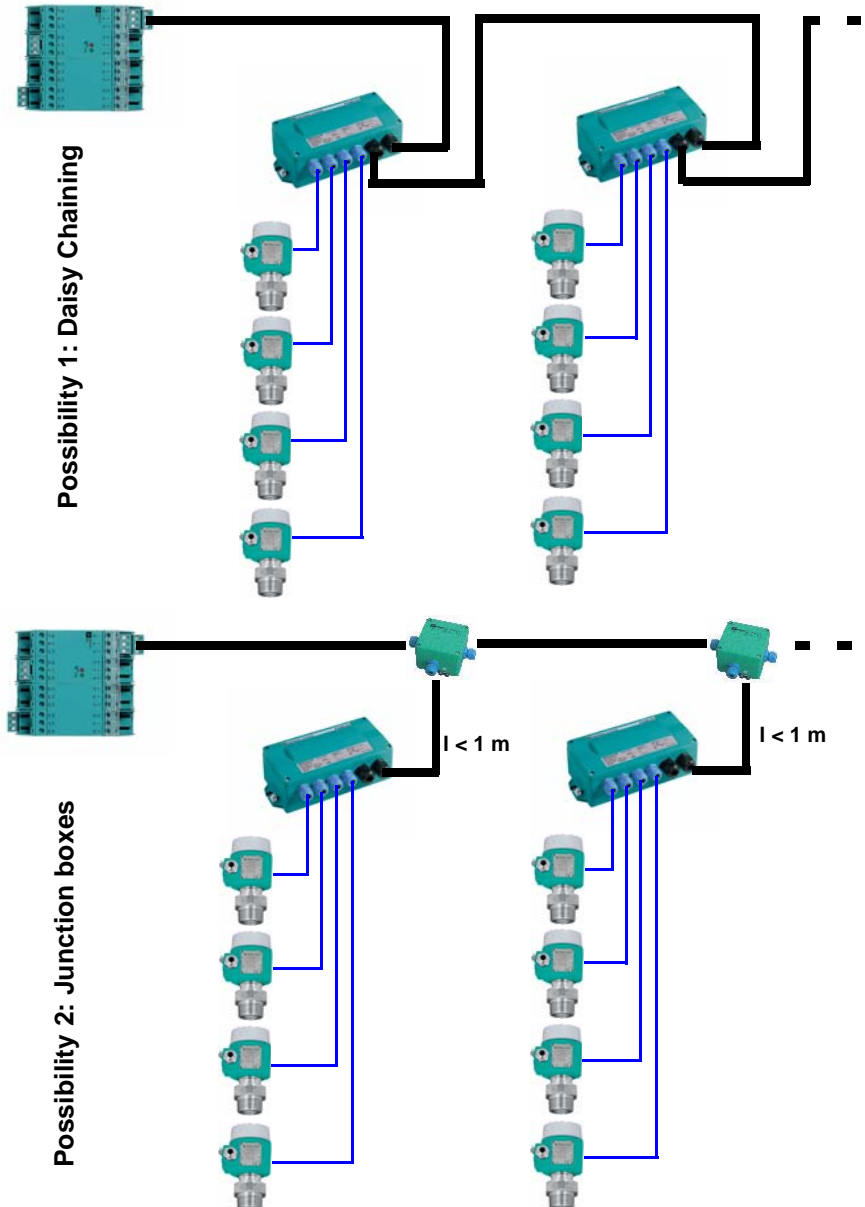

Figure 6.3: Topologies of non-intrinsically safe fieldbus segment

- By possibility 1, the trunk is directed into the FieldBarrier through one of the EEx e cable glands and back out through the second EEx e cable gland.
- By possibility 2, the FieldBarrier is connected to the trunk via a junction box Care must be taken here that the connection line between the junction box and FieldBarrier is < 1 m.

The transmitters integrated into the FieldBarrier are used to transfer impedances connected to the outputs to the trunk.



From the point of view of the trunk, each wired output of a FieldBarrier represents a spur.

Note

6.3 Dimensioning of a fieldbus segment

Dimensioning of a fieldbus segment is described in the

- Instruction manual/manual segment coupler.
- Instruction manual/manual Fieldbus components.

However, the calculation of maximum permissible line length described there is only valid if each fieldbus station of a segment has a linear characteristic input curve.



*The FieldBarrier has a **non-linear** characteristic input curve.*

Note

To simplify dimensioning of a fieldbus segment, Pepperl+Fuchs has developed the software tool "segmentchecker" that makes the necessary calculations. You can download this tool from the home page www.segmentchecker.com.

6.4 Terminating the trunk with a fieldbus terminating resistor.

The transmission line of a fieldbus application must be equipped with a fieldbus terminator. The fieldbus resistor must be mounted in such a manner as to ensure the longest possible line length between the segment coupler/power repeater/power conditioner and the fieldbus terminating resistor.

The P+F FieldBarrier Segment Checker for FOUNDATION Fieldbus software program shows where the fieldbus terminating resistor should be wired in.



An external terminating resistor can also be used.

Note

6.5 Mechanical dimensions

The mechanical dimensions are shown in the following illustration:

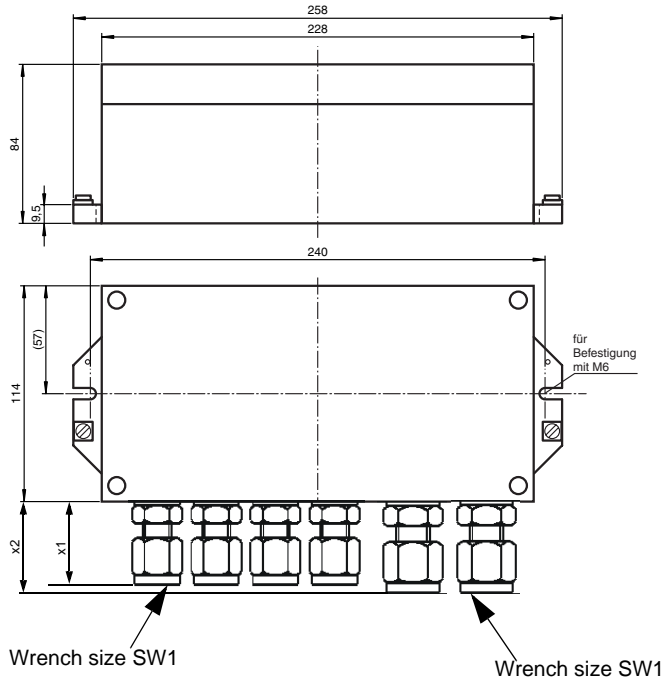

Figure 6.4: Mechanical dimensions of the F2D0-FB-Ex4.***

Dimensions X1, X2, SW1 and SW2 depend on the type of FieldBarrier. Please refer to the following table for dimensions:

Type	X1	X2	SW1	SW2
F*D0-FB-Ex4.CG	≤ 26 mm	≤ 28 mm	20	24
F*D0-FB-Ex4.CGB	≤ 22 mm	≤ 24 mm	20	24
F*D0-FB-Ex4.CGS	≤ 22 mm	≤ 24 mm	22	24
F*D0-FB-Ex4.CGAB	≤ 42 mm	≤ 42 mm	20	24

Table 6.1: Dimensions of the cable glands/cable bushings

6.5.1 Mechanical dimensions of the R version

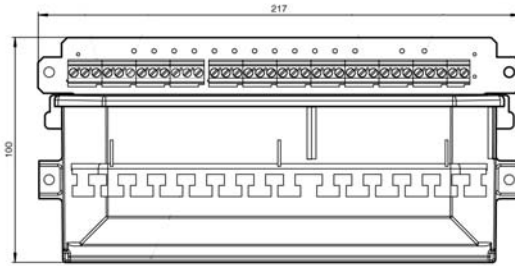

Figure 6.5: Mechanical dimensions of the R version

7 Commissioning the FieldBarrier

7.1 Mounting FieldBarriers

7.1.1 Mounting the FieldBarrier F*D0-FB-Ex4.***



Always observe the chapter 4 before placing the system in service.

Warning

You will find information on mounting in chapter 4.4. For information on permissible cable diameters, conductor cross sections and tightening torques of screws as well as cap nuts and cable glands, please refer to chapter 4.5.

The handling of the cable gland depends on the type in question.

7.1.2 Handling F*D0-FB-Ex4.CG cable glands

1. Insulate the covering of the cable up to about 160 mm.
2. Loosen the cap nuts from the FieldBarrier and push it onto the cable. Remove the seals from the FieldBarrier as well and push them onto the cable. The following table will indicate when Seal 1 should be used and when it is not required:

Type	Terminal area [mm]	Seal 1
M16 x 1.5	5 - 10	No
M20 x 1.5	5 - 8	Yes
M20 x 1.5	8 - 13	No

Seal 2 must always be used!

3. Push the seals that are used far enough over the cable so that the covering extends about 5 mm beyond the seal.
4. Insert the cable with the seals you are using into the cable gland of the FieldBarrier. Then tighten the cap nut. The tightening torques of cap nuts depend on what type of cable is used and must therefore be determined by the user. As a rough guide for the FieldBarrier of type F*D0-FB-Ex4.CG you may use 2.5 Nm for the cap nut and 3.75 Nm for the lower part.



Step 1

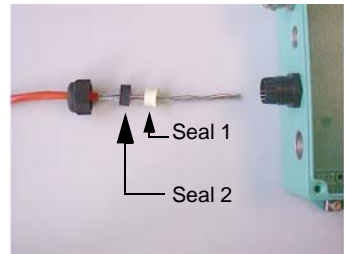

Step 2



Step 3

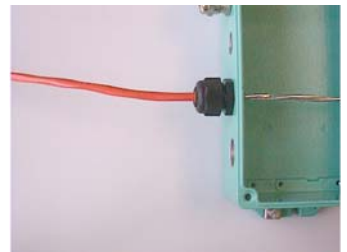

Step 4

7.1.3 Handling the F*D0-FB-Ex4.CGB and F*D0-FB-Ex4.CGS cable gland

1. Insulate the covering of the cable up to about 160 mm.
2. Loosen the cap nuts from the FieldBarrier and push it onto the cable.
3. Remove the seals from the inside plastic part as well and push them onto the cable. Move the inside plastic part far enough over the cable that the covering is completely surrounded by the seal. The covering must not stand out over the end of the plastic inner part.
4. Pull the shield over the inside plastic part and shorten it to the correct length. The shield should protrude about 3 to 4 mm beyond the O-ring.
5. Insert the cable with the inside plastic part into the lower part of the cable gland.
6. Then tighten the cap nut.

The tightening torques of cap nuts depend on what type of cable is used and must therefore be determined by the user.

As rough guides for FieldBarrier type F*D0-FB-Ex4.CGS you may use 4.17 Nm for the cap nut and 6.25 Nm for the lower part.



Step 1



Step 2



Step 3

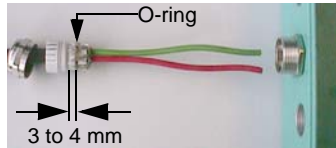

Step 4



Step 5



Step 6

08/2007 122239

7.1.5 Mounting the stop plug

A cable gland that is not being used must be provided with a stop plug to maintain the protection class.

When mounting the stop plug, the cable gland must be provided with all seals.

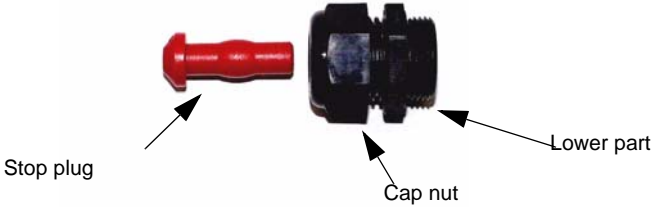

1. Remove the cap nut from the lower part if this has not already been done.
2. Push the stop plug up into the cable gland as far as it will go.
3. Tighten the cap nut securely. Note the tightening torques in chapter 7.1.2 and in chapter 7.1.3.

7.1.6 Mounting the FieldBarrier RD0-FB-Ex4



Always observe the operating instructions when placing the system in service. You will find these in of this manual chapter 4.

Warning

You will find information on mounting in chapter 4.4. You will find information on permissible conductor cross sections and tightening torques for screws in chapter 4.5.

7.2 FieldBarrier connections

The layout of the connections for the FieldBarrier depends on what type you are using

Terminal	Function
1B, 2B	Capacitor jumper wire (jumper wire present ==> hard grounding)
3+	trunk +
4-	trunk -
5S	trunk shield
6S	trunk shield
7-	trunk -
8+	trunk +
10+	Output 1 +
11 -	Output 1 -
12S	Output 1 shield
13+	Output 2 +
14-	Output 2 -

08/2007 122329

Terminal	Function
15S	Output 2 shield
16+	Output 3 +
17-	18S
18S	Output 3 shield
19+	Output 4 +
20-	Output 4 -
21S	Output 4 shield

7.3 Grounding

Please note the grounding information in chapter 4.6 of these operating instructions/manual.

7.4 Fieldbus termination

Fieldbus terminating resistor *LED displays*

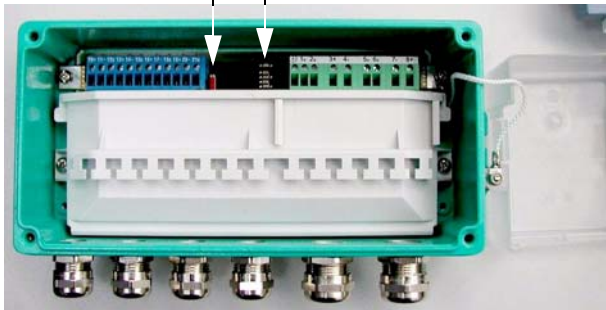

Figure 7.1: Displays and operating elements

The layout of the display and operating elements of the FieldBarrier F*D0-FB-Ex4*,*** is identical of the layout in version RD0-FB-Ex4.

The fieldbus terminating resistor should be turned on if the FieldBarrier is the last station on a non-intrinsically safe fieldbus segment.



Note

Please note the information on termination in chapter 6.4

7.5 Displays and error messages.



*The LEDs cannot be seen with the F*D0-FB-Ex*.*** FieldBarrier unless the cover of the FieldBarrier has been removed.*

Note

LED	Function
PWR, green is lit	A suitably high power supply is present on the non-intrinsically safe fieldbus segment.
1 to 4, red flashing	There is a short circuit present on the corresponding output.

PROCESS AUTOMATION – PROTECTING YOUR PROCESS



Worldwide Headquarters

Pepperl+Fuchs GmbH
68307 Mannheim · Germany
Tel. +49 621 776-0
E-mail: info@de.pepperl-fuchs.com

For the Pepperl+Fuchs representative
closest to you check www.pepperl-fuchs.com/pfcontact

www.pepperl-fuchs.com

Subject to modifications
Copyright PEPPERL+FUCHS • Printed in Germany

 **PEPPERL+FUCHS**
PROTECTING YOUR PROCESS

122329 / TDOCT-0186EENG

11/2007